

JOB NAME

ITEM NO.

SUBMITTED AS SHOWN

SUBMITTED AS NOTED

SEE ATTACHED FOR
SUBMITTED MODIFICATION



ADA COMPLIANT

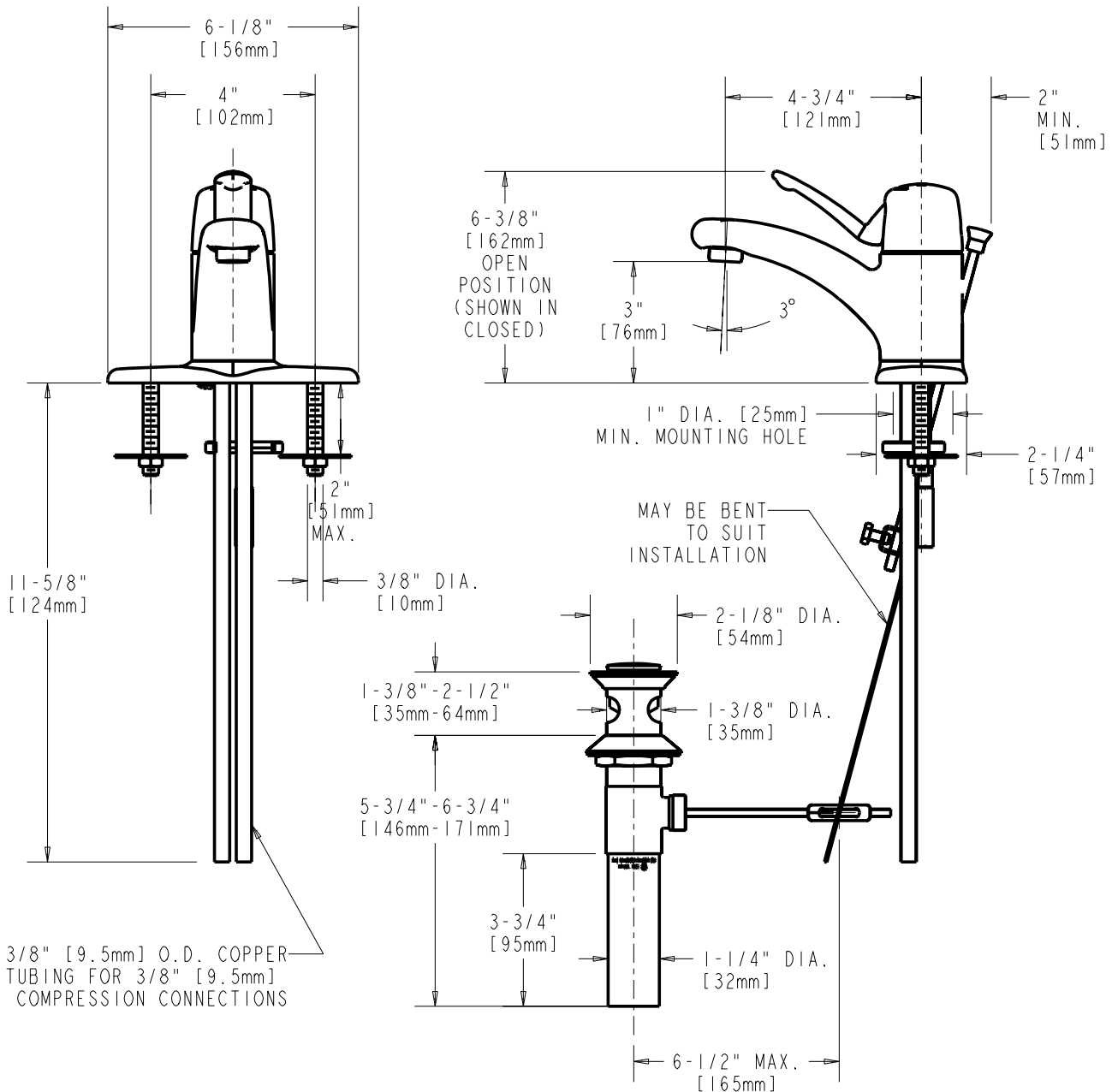

TECHNICAL DATA

- MARATHON DECK MOUNTED FITTING WITH POP-UP
- 4-3/4" CAST BRASS SPOUT
- METAL LEVER HANDLE
- FINISH: CHROME PLATE
- CERAMIC MIXING CARTRIDGE
- MAX. MIXING ANGLE 120°
- TEMPERATURE LIMIT STOP

- VOLUME CONTROL
- E12 SOFTFLO AERATOR
- 2.2 GPM [8.3 L/min.] FLOW RATE
- 6-1/8" X 2-1/4" COVER PLATE
- ASME A112.18.1M COMPLIANT
- CSA B125 COMPLIANT
- NSF 61 COMPLIANT

DATE: 10-15-04

BY: SID

CHK'D: CG

APP'D:

REV: D

2201-4

ROUGHING IN DIMENSIONS MAY VARY AND ARE SUBJECT TO CHANGE. NO RESPONSIBILITY IS ASSUMED FOR USE OF SUPERCEDED OR VOIDED DATA.